



Drive Control DCP



DCP is a control system for hydrostatic drives and incorporates extensive options. Its entire performance such as acceleration, braking, speed (speed control and creep speed) is controlled by electronics. At the same time, the diesel motor is monitored and the decrease of performance is adapted to the current driving situation. Pre-setting the diesel rotary frequency (ramps, fixed values) makes it possible to control the hydrostatic drive individually for all operation modes and relieves the driver. The entire control system is monitored by an additional microcontroller. This safety feature together with the CAN bus makes the DCP control system versatile and usable for complex tasks.

The DCP is constructed based on the hardware platform HCY. The hand terminal MT and the PC program ConDoc - Control& Document® serve to adapt and input the machine-specific data.

For routine control, the operating data can be sent via CAN to a display (DCD). The display puts on view:

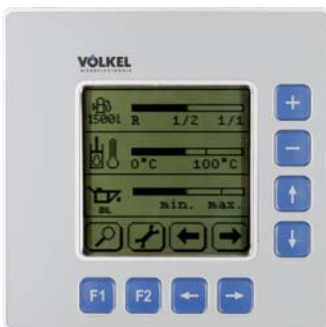

- Driving speed
- Diesel revs
- Load of diesel engine
- Operating mode



The control system is protected by a robust aluminium housing (IP65).



DCP Connection diagram

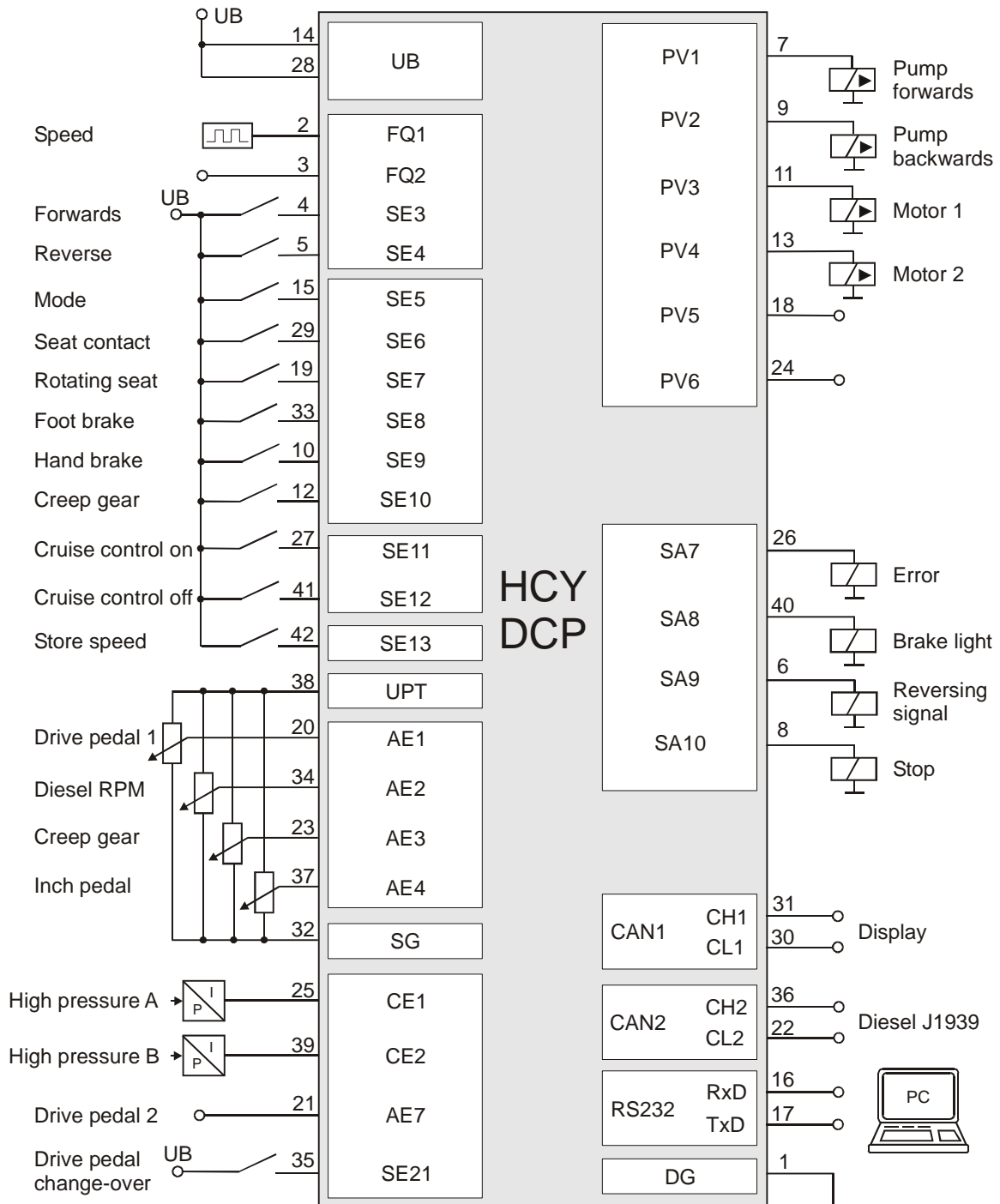



DCP Block diagram

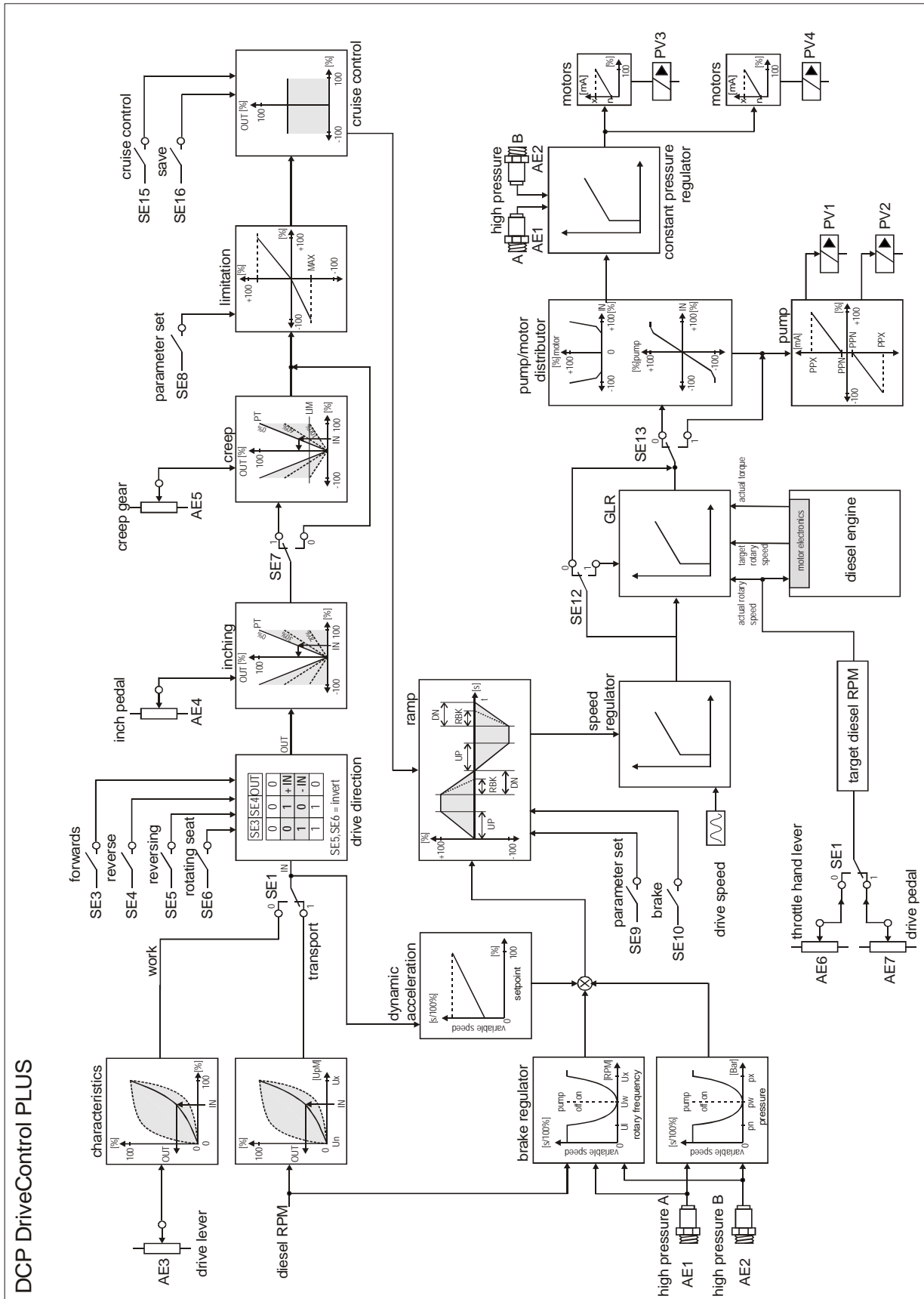



DCP Function description

Operation mode work/transport

- Operating mode selection by switches

Working mode

- Driving at a fixed diesel rotary frequency
- Selection of the diesel rotary frequency using a separate potentiometer
- Actuation of the hydrostat using a control lever or a pedal

Transport mode

- Adjustment of diesel rotary frequency using the throttle pedal
- Driving the hydrostat dependent on the diesel rotary frequency

Characteristic curves

- The desired value generation for the hydrostat can be made linear or by the hyperbolic function and can be set separately for each operation mode
⇒ leads to sensitive starting
- Transport mode: separately adjustable start/ stop function for hydrostat dependent on the diesel rotary frequency
⇒ drive at the lowest diesel rotary frequency necessary (minimum noise development and consumption)
- Diesel rotary frequency range can be set separately for each operation mode

Selection of drive direction

- Selection of drive direction using two switches
- If there is a rotating seat in the vehicle: changing the driving direction for each seat position
- Change-over of drive direction in working mode using a reversing switch

Inching

- Reduction of the driving speed using the inch pedal.

Creep gear

- Limitation of the maximum speed using a creep speed potentiometer or a fixed value
⇒ Improvement of sensitive driving in the lower speed range
- Function can be activated via a switch
- Maintenance of the full pedal range

Cruise control

- Recalling the saved speed
- Manual increase or reduction of the speed using the keys



DCP Function description contd.

Brake pressure controller

- Brake pressure control dependent on the motor absorption volume
- ⇒ Results in constant deceleration during the entire reduction process

Diesel overspeed regulator

- Protects the diesel against overspeed during hydrostatic deceleration
- Reduction of the noise development during hydrostatic deceleration

Ramps

- Damping the hydrostat adjustment
- Separate acceleration, reduction and braking ramp times according to the operation mode

Dynamic acceleration

- Acceleration dependent on the pedal position

Load limit sensing control

- Control of power withdrawal by diesel engine
- ⇒ Protection against stalling the diesel engine

Constant pressure controller

- Maintenance of traction power when driving on slopes

Speed controller

- Control of the vehicle's speed

Speed limitation

- Speed limitation for each operating mode and direction

Diesel management

- Diesel management possible using the SAE-J1939 CAN protocol

Functionality when sensors are defective

- Limited functionality when the pressure sensors are defective
- Limited functionality when the diesel rev sensor is defective

Safety functions

- Protection against undesired changes in direction
- Protection against undesired changes of the operating mode
- Starting lock after braking manoeuvre until still, dependent on the setting value source
- Starting lock for setting value errors during switch-on time



HCY Housing dimensions

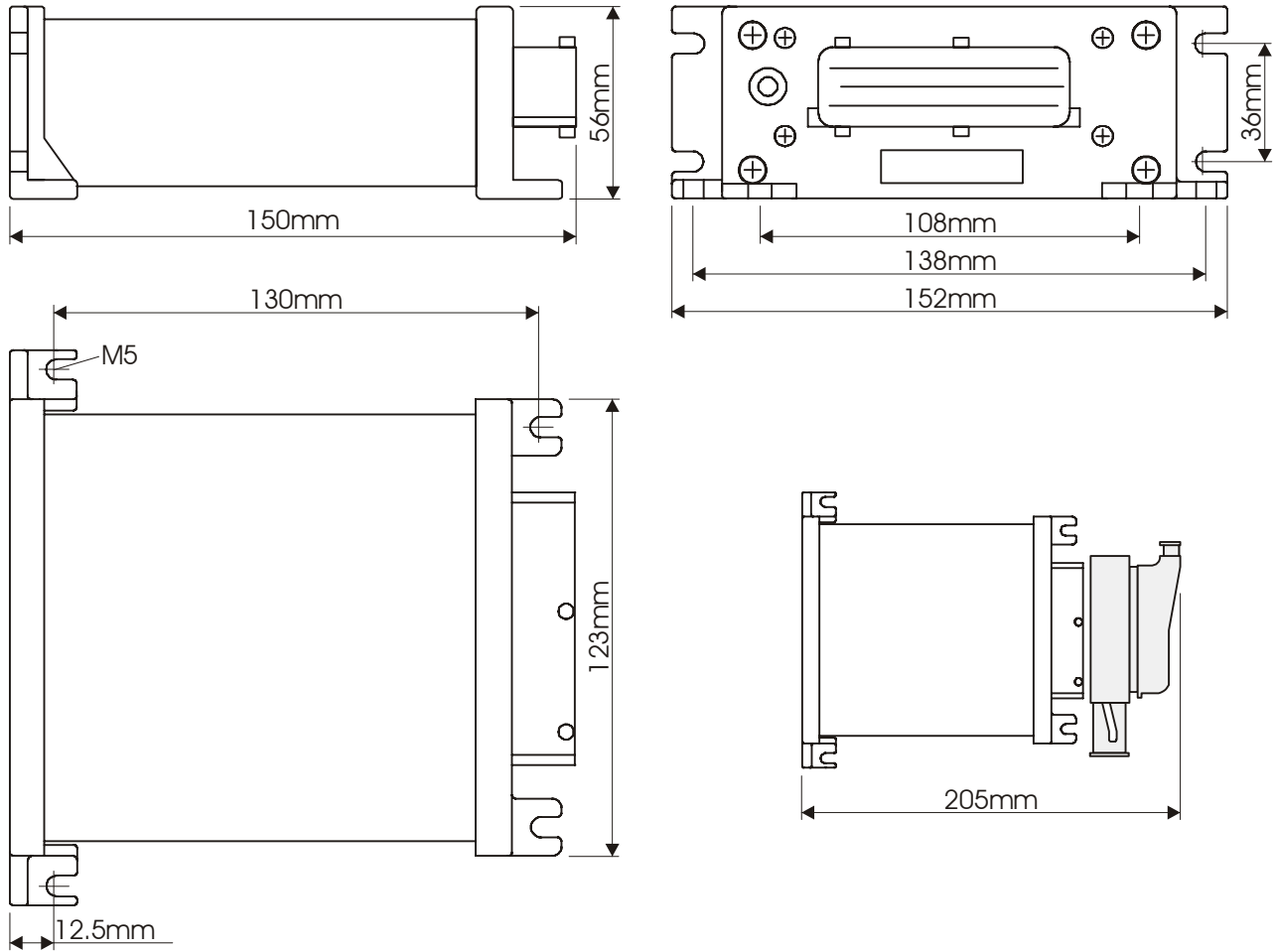

HCY Connector

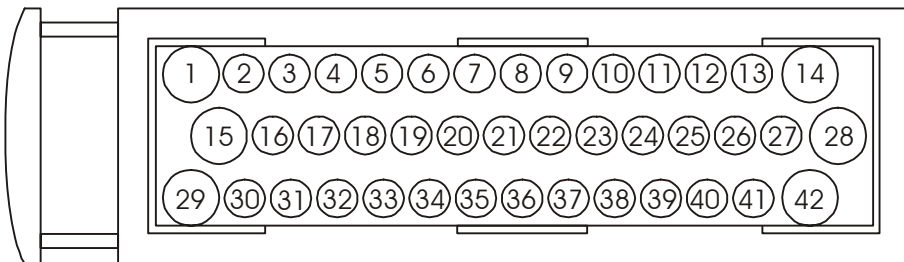



DCP Functional safety

Safe control systems need safe hardware and safe software.

Safe hardware:

- 2 microcontrollers monitor each other
- Each microcontroller has separate voltage regulation, cycle operation and its own watchdog
- Additional means of switching off using a safety relay according to the principle of quiescent current
- Monitoring the supply voltage and reverse measurement of all outputs

Structural diagram:

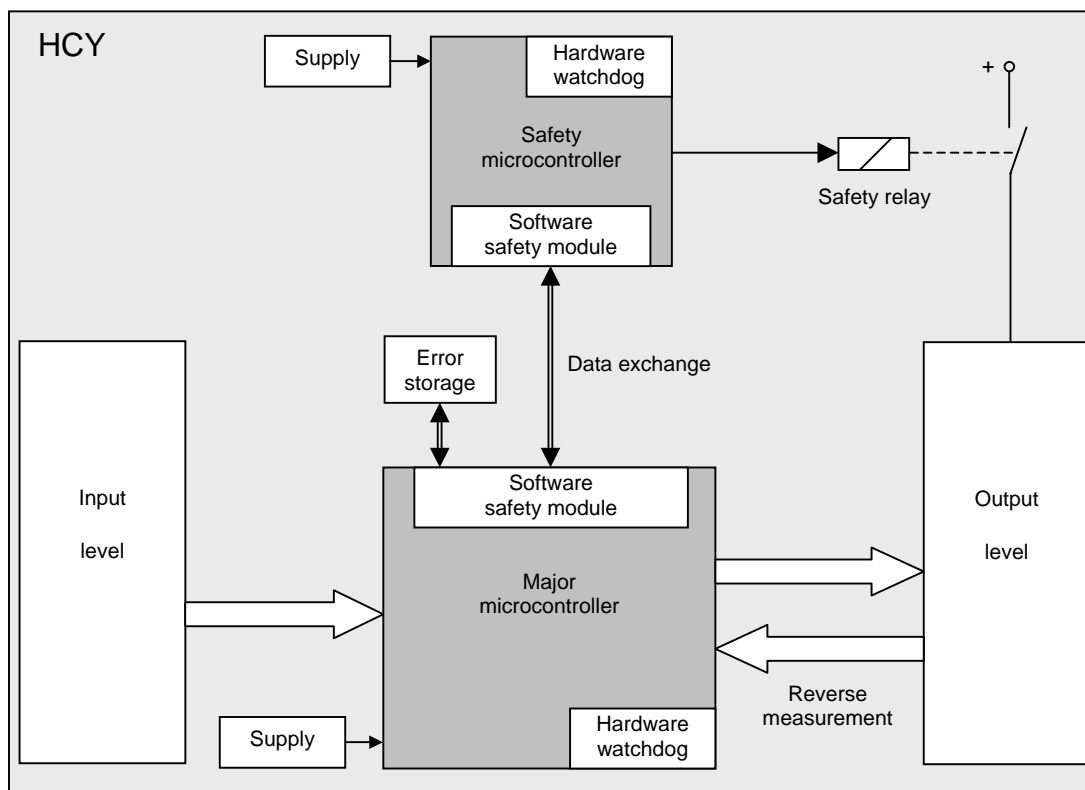

Safe software:

- Mutual work flow control by permanent data exchange with total-checking control
- Checking ROM and RAM by read and write tests with check sum calculation with the power ON
- Various possibilities to monitor the inputs and outputs (e.g. recognition of cable breaks and short circuits)
- Plausibility checks for important parameters by logical combination and checking limit values

**DCP Pin assignment**

1	DG	Supply, minus (earth)
14	UB	Supply, plus (12V / 24V)
28	UB	Supply, plus (12V / 24V)
2	SE1 / FQ1	Switch input 1 / frequency input 1 (-5.. 32V)
3	SE2 / FQ2	Switch input 2 / frequency input 2 (-5.. 32V)
4	SE3 / FQ3	Switch input 3 / frequency input 3 (-5.. 32V)
5	SE4 / FQ4	Switch input 4 / frequency input 4 (-5.. 32V)
15	SE5 / FQ5	Switch input 5 / frequency input 5 (2,5V)
29	SE6 / FQ6	Switch input 6 / frequency input 6 (2,5V)
19	SE7 / FQ7	Switch input 7 / frequency input 7 (2,5V)
33	SE8 / FQ8	Switch input 8 / frequency input 8 (2,5V)
10	SE9	Switch input 9 / safety input
12	SE10	Switch input 10 / safety input
27	FQ9P / SE11	Switch input 11 / pickup H
41	FQ9M / SE12	Switch input 12 / pickup L
42	FQ10 / SE13	Switch input 13 / clamp W
38	UPT	Output 5V / 8V
20	AE1 / SE14	Analogue input 1 (10V) / Switch input 14
34	AE2 / SE15	Analogue input 2 (10V) / Switch input 15
23	AE3 / SE16	Analogue input 3 (10V) / Switch input 16
37	AE4 / SE17	Analogue input 4 (10V) / Switch input 17
32	SG	Signal earth
25	AE5/CE1/SE18	Analogue input 5 (5V/10V) / 4 to 20 mA Current input / Switch input 18
39	AE6/CE2/SE19	Analogue input 6 (5V/10V) / 4 to 20 mA Current input / Switch input 19
21	AE7/CE3/SE20	Analogue input 7 (5V/10V) / 4 to 20 mA Current input / Switch input 20
35	AE8/CE4/SE21	Analogue input 8 (5V/10V) / 4 to 20 mA Current input / Switch input 21
7	PV1P / SA1	Proportional output 1 / Switch output 1
9	PV2P / SA2	Proportional output 2 / Switch output 2
11	PV3P / SA3	Proportional output 3 / Switch output 3
13	PV4P / SA4	Proportional output 4 / Switch output 4
18	PV5P / SA5	Proportional output 5 / Switch output 5
24	PV6P / SA6	Proportional output 6 / Switch output 6
26	SA7	Switch output 7
40	SA8	Switch output 8
6	SA9	Switch output 9
8	SA10	Switch output 10
31	CH1	CAN1 line H
30	CL1	CAN1 line L
36	CH2	CAN2 line H
22	CL2	CAN2 line L
16	RXD	RS232 Receive cable for the hand terminal or the PC
17	TXD	RS232 Send cable for the hand terminal or the PC

**DCP Technical data**

Dimensions:	152mm x 150mm x 56mm
Weight:	700g
Plug connections:	Multiple plug, AMP 1-0967280-1, 42 contacts
Power supply:	UB = 8 ... 32V
Surrounding temperature:	-40 ... 85°C
Current input:	Approx. 160mA at 24V (plus output current)
Parameter settings:	Using the hand terminal or a PC (RS232)
Microcontroller:	C167CS / 40MHz
Program memory:	1MByte flash EPROM
Data memory:	128kByte RAM
Parameter memory:	64kBit EEPROM
Safety microcontroller:	C505CA / 4MHz
Inputs:	<p>4 Digital switch entries with 4.7kΩ pull down/pull up resistors. Switching thresholds which can be switched in pairs in the range of -5 ... 32V. Suitable as frequency inputs up to 10kHz. Also appropriate for Namur sensors due to 1kΩ pull down which can be additionally connected.</p> <p>6 Digital switch entries with 4.7kΩ pull down resistors and switching thresholds which can be set in the range of 0 ... 32V. 4 of these can be used as frequency inputs up to 4KHz with fixed switching thresholds: $U_{on} = \text{approx. } 2.9V$, $U_{off} = \text{approx. } 1.5V$. 2 are also evaluated additionally by the safety controller.</p> <p>1 Rev sensor input, pickup, $f_{max} = 10kHz$, Signal level: $U_{ss} = 400mV$ at 1kHz, becomes less sensitive at higher frequencies. Both connections can also be used as additional digital switch entries with 4.7kΩ pull down resistors and thresholds which can be set in the range of 0 ... 32V.</p> <p>1 Clamp W, frequency input, $f_{max} = 2kHz$, switching thresholds: $U_{on} = 75\%$ von UB, $U_{off} = 25\%$ of UB, 4.7kΩ resistance to earth. Can also be used as a digital switch entry with thresholds which can be set in the range of 0 ... 32V.</p> <p>4 Analogue inputs for the current range 0 ... 10V with 10 bit resolution and 100kΩ input resistance. Can be configured as switch entries with thresholds which can be set in the ranges 0 ... 10V and 4.7kΩ pull down.</p>



DCP Technical data contd.

Inputs:	4	4 ... 20mA current supplies with 220Ω burden to earth and 10 bit resolution. Overload protected. Can be switched as an analogue input with a voltage range from 0 ... 5V or 0 ... 10V with 10 bit resolution and 100kΩ input resistance. Can also be configured as a switch entry with 4.7kΩ pull down and thresholds which can be set in the range 0 ... 10V.
Outputs:	6	Proportional solenoid outputs, each for a maximum of 3A.
	4	Switch outputs, each for a maximum of 3A.
	1	Power supply output with 5V or 8V for Namur sensors and potentiometers.
	1	Safety relay for switching off the 6 proportional outputs and the 4 switch outputs. The safety relay can be switched off using the safety microcontroller.
Interfaces:		1x RS232, 2x CAN
Safety:		Two microcontrollers, mutual control, each with Microcontroller watchdog Double voltage regulation Double cycle generation Safety cut off via relay No terminals with sockets used Reverse pole protection Ventilation membrane Protection system IP65, IP69K
EMV:	Road vehicles:	Directive 72/245/EWG (95/54/EG), ISO 10605, ISO 7637-1, ISO 7637-2, ISO 7637-3
	Construction machinery:	DIN EN 13309, ISO 7637-3
	Agricultural and forestry vehicles:	Directive 75/322/EWG (2001/3/EG), DIN EN ISO 14982, ISO 7637-3
	Industrial application:	DIN EN 61000-6-2, DIN EN 61000-6-4

We reserve the rights to make technical changes · Status 8/06